

FPGA Based Modulation and Control of Paralleled Z source Inverter Applicable for DG Systems

¹Gopika T G, ²Pradip C

¹PG Student [PE], Dept. of EEE, NSS College of Engineering, Palakkad, Kerala, India

²Associate Professor, Dept. of EEE, NSS College of Engineering, Palakkad, Kerala, India

Abstract: This paper presents a FPGA based modulation scheme and a close loop controller is designed for paralleled Z-source inverter systems which is applicable for alternative energy sources. A modulation scheme is proposed based on simple shoot-through principle with interleaved carriers to give enhanced ripple reduction in the system. FPGA based programming language is used to generate twelve switching pulses and shoot through pulse. A control method is proposed to equalize the amount of power injected by the inverters in the grid-connected mode. The modulation and controlling methods are proposed to have maintainability, and improved reliability of supply can be achieved. DsPic based system is used to obtain the control circuit. The performance of the proposed paralleled Z-source inverter configuration is validated with simulations carried out using Matlab. Moreover, a prototype is build to obtain the experimental verifications.

Keywords: Controller, DG System, FPGA, Grid connected mode, Parallel Inverters, Simple shoot through, Z Source.

I. INTRODUCTION

Distributed generation (DG) systems will allow power generation at the point of consumption. It is also known as on-site generation which can eliminate the cost, complexity, interdependencies, and inefficiencies associated with transmission and distribution. The system shifts the control to the consumer. The world needs distributed generation tapped through renewable energy resources, because that is clean and continuous. Initially distributed generation meant internal combustion based power generation (e.g. diesel generators). They were affordable, and in some cases reliable, however depletion of petroleum resources and threat caused to environment due to its usage has to be considered. The recent trend to meet an ever-increasing energy demand is by generating power through renewable energy and adopting to distributed generating systems.

It is necessary to convert the output voltage and frequency of these sources to standard values which can be compatible with domestic and industrial loads. A power conditioner can achieve the goal. There are two types of inverters that are being used commonly; voltage-source inverter (VSI) and current-source inverter (CSI). The inverters have a limited operating range, even though both are widely used in DG applications. This difficulty can be overcome by connecting it with a separate dc-dc converter stage in the front end. Hence the system can operate in both buck and boost modes. The topology is commonly known as a two-stage inverter. However, two-stage inverters are not cost effective, and controlling is difficult. A solution to this problem can be achieved through a Z-source inverter was recently proposed. The Z-source inverter is a single-stage topology. It can overcome the limitations of the conventional converters. It consists of "X"-shaped impedance network formed by two capacitors and two inductors and provides unique buck boost characteristics. Moreover, the need of dead time would not arise with this topology. This system is especially useful with high-capacity

generation in which an inverter system based on single power modules would not be able to handle the capacity. The capacity can be increased by paralleling the devices. Paralleled inverters can operate independently as they are normally built with modular independence. Paralleled inverters can be found in multi-transformer and multiple inverter systems or multiple carrier multi-inverter systems. They are used to reduce the pulse width modulation switching frequency and thereby reducing the harmonics. There are many ways to connect inverters in parallel. Some of them are: independent inverters with separate dc sources and to connect the inverters into a common dc source.

In the case of a Z-source inverter, it requires more than one independent Z-source impedance network. A common Z-source with parallel inverters is proposed. The controlling is the most difficult part due to the presence of current flow between the inverters. This has to be considered in designing modulation and controllers for paralleled Z-source inverter systems. The system focuses on designing modulation and controllers for parallel connected Z-source inverters that can be used for interfacing renewable energy system.

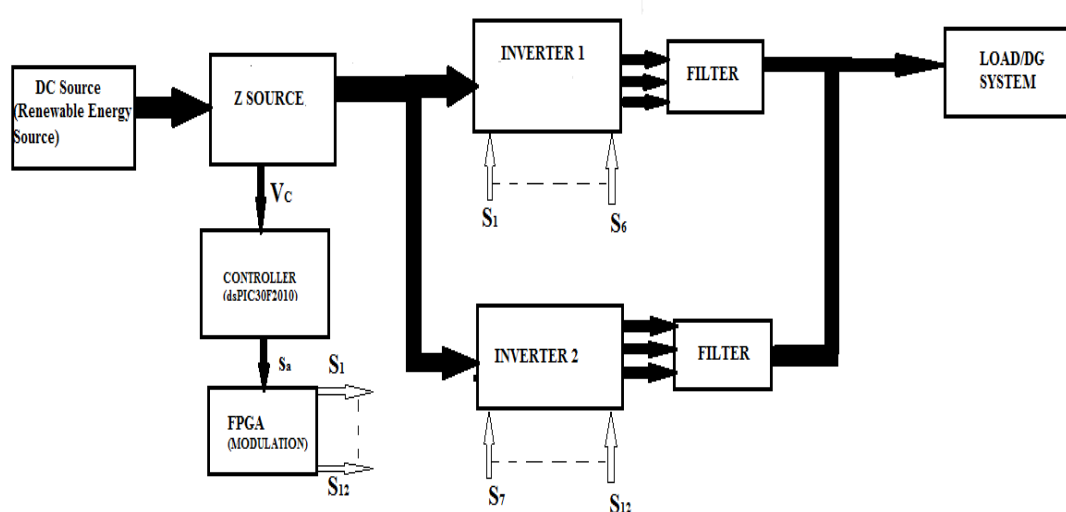

Fig 1: Block diagram of the proposed system

II. LITERATURE REVIEW

Recently, solar has become a popular distributed generation option. There are many types of DG energy sources that produce electrical power with different voltages at different frequencies. Such disparity in output characteristics can be found even in sources like fuel cells and solar cells; both of them have a high potential to be dominant DG sources in the future. Distributed generation systems are usually connected to the grid using power electronic converters. Power delivered from such DG sources depends on factors like energy availability and load demand. The converters used in power conversion do not operate with their full capacity all the time. The unused or remaining capacity of the converters could be used to provide some ancillary functions like harmonic and unbalance mitigation of the power distribution system. So this system gains very much important nowadays, because the future scope of the system lies in the harmonic mitigation. Harmonics are currents or voltages with frequencies that are integer multiples of the fundamental power frequency. Power quality issues can be addressed in different ways. Inverters are generally configured to operate in grid 'voltage-following' mode and to disconnect DG when the grid voltage moves outside set parameters, it is known as grid-derived voltage fluctuations. Voltage imbalance is another issue which occurs when the amplitude of each phase voltage is different in a three-phase system or the phase difference is not exactly 120° . Normally the centralized power networks involve power flow in one direction only, it is from power plant to transmission network then to distribution network and to load. Voltage regulators are also used to compensate for voltage drop and maintain the voltage in the designated range along the line. Voltage rise and reverse power flow causes harmonics and it may damage the whole system. Poor power factor on the grid increases line losses and makes voltage regulation as a difficult job. The inverters are configured to be voltage-following and have unity power factor, while inverters in voltage-regulating mode provide current that is out of phase with the grid voltage and so provide power factor correction.

A single-stage topology in which both the buck and boost modes are possible. The buck–boost characteristic is obtained with the help of distinct impedance network. Also, it's having good electromagnetic interference properties. Because it does not need dead time. Most of the research work published in Z source network are based on controlling and in open-loop nature, but a closed-loop controller is designed with a sliding-mode control, in the inverter side with the help of space vector modulation. However, these are not considering the dynamics of the Z-source network. In order to drive sensitive loads and to connect to the utility, it is necessary to regulate the output voltage and current of the Z-source inverter. Furthermore, it is important to ride through voltage dips and power frequency harmonics. Hence, designed controllers should be able to track the reference while rejecting the disturbances effectively. Finally, experimental results are presented to corroborate the disturbance-rejection and reference-tracking capability of the designed closed-loop controlled Z-source. This project focuses on modulation and controller design for parallel connected Z-sourced inverters that can be used for distributed generation application. The controllers are designed in to stabilize the dc link voltage.

2.1 EQUIVALENT CIRCUIT AND OPERATING PRINCIPLE:

The unique feature of the Z-source inverter is that the output ac voltage can be any value between zero and infinity regardless of the input dc voltage. The Z-source inverter is a buck–boost inverter which is having wide operating range. The traditional V- and I-source inverters are having limited operating range. In the three-phase Z-source inverter is having nine permissible switching states. But the traditional three-phase V-source inverter has eight switching states. The traditional three-phase V-source inverter has six active vectors and two zero vectors respectively. However, the Z-source inverter bridge has one extra zero state called shoot through state. This one extra zero state provides the unique buck–boost feature to the inverter.

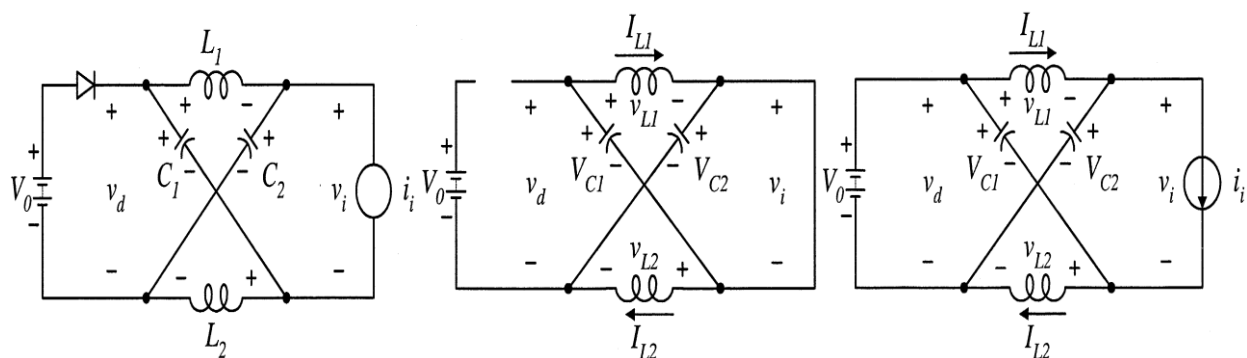

Fig.2 (a)Equivalent circuit of the Z source inverter (b) dc link when the inverter bridge is in the shoot-through (c) eight non-shoot through switching states

Fig. 2: shows the equivalent circuit of the Z-source inverter. Note that the inverter bridge can be also represented by a current source with zero value (i.e., an open circuit) when it is in one of the two traditional zero states. During shoot through state diode is reverse biased and power flow is from capacitors to inductor through the switches. During active state diode get forward biased and power flows from dc source and inductance to load and capacitors. This operation make the network most desirable.

Assuming that the inductors L_1 and L_2 and capacitors C_1 and C_2 have the same inductance and capacitance. Hence the Z-source network becomes symmetrical. From the symmetry we can obtain the equations such as

$$V_{C1} = V_{C2} = V_C \quad v_{L1} = v_{L2} = V_L \quad (1)$$

When the inverter bridge is in the shoot-through zero state for an interval of T_0 , during a switching cycle T , and from the equivalent circuit, Fig. 2.1(b)

$$v_L = V_C v_d = 2V_C V_i = 0 \quad (2)$$

Now consider that the inverter bridge is in one of the eight non shoot through states for an interval of, T_1 during the switching cycle T , From the equivalent circuit, Fig. 2.1(c)

$$v_L = V_{dc} - V_C, \quad v_d = V_0, \quad v_i = V_C = v_L = 2V_C - V_{dc} \quad (3)$$

Where ' V_{dc} ' is the dc source voltage and time period 'T',

$$T = T_0 + T_1 \quad (4)$$

The average voltage of the inductors over one switching period should be zero in steady state, from (2.2) and (2.3), thus, we have

$$V_L = \overline{v_L} = \frac{(T_0 \times V_C) + T_1(V_{dc} - V_C)}{T} = 0 \quad (5)$$

$$\frac{V_C}{V_{dc}} = \frac{T_1}{T_1 - T_0} \quad (6)$$

$$V_{C1} = V_{C2} = V_C = \frac{1 - \frac{T_0}{T}}{1 - 2\frac{T_0}{T}} V_{dc} \quad (7)$$

Similarly, the average dc-link voltage across the inverter bridge can be found as follows:

$$V_{dc \text{ link}} = \overline{v_{dc \text{ link}}} = \frac{T_0 \cdot 0 + T_1(2V_C - V_{dc})}{T} = \frac{T_1}{T_1 - T_0} V_{dc} = V_C \quad (8)$$

The peak dc-link voltage ($\overline{v_{dc \text{ link}}}$) across the inverter bridge is

$$\overline{v_{dc \text{ link}}} = V_C - v_L = (2V_C - V_0) = \frac{T_1}{T_1 - T_0} V_0 = BV_0 \quad (9)$$

$$B = \frac{T}{T_1 - T_0} = \frac{1}{1 - 2\frac{T_0}{T}} \geq 1 \quad (10)$$

"B" is the boost factor. The output peak phase voltage from the inverter can be expressed as

$$\widehat{v_{o_ph}} = M \frac{\overline{v_{dc \text{ link}}}}{2} \quad (11)$$

Where M is the modulation index. Using (8), (10) can rewrite as

$$\widehat{v_{o_ph}} = M \cdot B \frac{V_{dc}}{2} \quad (12)$$

$$\widehat{v_{o_ph}} = B_B \frac{V_{dc}}{2} \quad (13)$$

$$B_B = M \cdot B = (0 \sim \infty) \quad (14)$$

For the traditional V-source PWM inverter,

$$\widehat{v_{o_ph}} = M \cdot \frac{V_{dc}}{2} \quad (15)$$

Equation (13) shows that the output depends on the boost factor B_B . It determines the mode of operation, that is buck or boost. Comparing the two equations (12) and (15) it is seen that with z source network the operating range became wide. The boost factor can be controlled by shoot through duty cycle. Note that the shoot-through zero state does not affect the PWM control of the inverter, because it equivalently produces the same zero voltage to the load terminal. The available shoot-through period is limited by the zero-state period that is determined

III. MODULATION AND CONTROL

Inverters are modulated with the help of carrier-based PWM methods because they are simple and easy to implement. Three types of carrier-based modulation schemes are proposed to modulate single-stage Z-source inverter. First method is the simple boost modulation. In which the shoot-through period is fully inserted within the null period, and this is achieved simply by comparing a constant reference value with the carrier signal. The main drawback of this method is, it increases the number of switchings per half carrier cycle. With the second method, the total null period is converted as shoot-through period and is known as maximum boost control. It avoids the switching issue, but dynamic performance under transient conditions are very poor. The modulation method proposed in has shoot-through period carefully inserted between the state changes from active to active and active to null. This minimizes the number of switchings per half carrier cycle and achieve improved dynamic performance.

Here two inverters are connected dc source through a common Z-source network. Hence, the proposed modulation schemes may suit to new topology. There are two possible ways to modulate the system. The first and easy method is to modulate the two inverters from a common carrier with simple boost or maximum boost technique. These method will results in desired modulation scheme. But they may require large filter inductors. However, the second method the possibility to over boost is there. The second method is to use two interleaved carriers. This method has been commonly used. Many paralleled inverter structures and produces a resultant system output with good output-voltage quality and lowripple current.

Now with this method, both inverters will go to null states simultaneously which may results in additional conduction paths. Moreover, in modulating the Z-source inverters, shoot-through period should be included without disturbing the functionality of the inverters .It is also important to maintaining the correct volt-second balance. As discussed above with interleaved carrier method minimum switching is not possible. It will affect the volt-second balance. As Therefore, simple boost modulation is selected. However five reference signals are used and they consist of three reference sinusoidal signals and two shoot through references. With this technique, the two inverters work complementary, it means when one inverter reaches the zero state with(0 0 0), the other becomes (1 1 1)active high. The null state is obtained whencarrier signals should be greater than the shoot-through references.

When any oneinverter goes into (0 0 0) state, all the bottom switches are in ON position and it leads to the shoot through, at that time any one of the top switches also needs to be switched ON. Similarly, when the inverter goes into (1 1 1)state, all the upper switches are turned ON while at least one of the bottom switches needs to be switched ON. As is needless to apply shoot-through in all three arms simultaneously, it would be better if shoot-through is spread among arms to avoid the overstressing of a particular switch. This switching signal conditioning is carried out with a field-programmable logic device in the practical prototype. Here a modulation technique with field programmable gate array(FPGA) is proposed. By programmed implementation, the conditions can be can be changed as per the requirement easily.. It will results in a simple way of modulating a complex system.

A shoot through is applied simultaneously for both of the inverter, it allows both inverters to operate independently, thus facilitating paralleling of additional modules if require. Thereby improve capacity and redundancy. Also, inverters share the shoot through current, thus reducing the possibility of overstressing of a particular inverter. Switching signals are labeled with R, Y, or B to indicate the phase and subscript "u" or "L" to indicate the top or bottom switching signal and subscript 1 or 2 indicates the inverter number. For example, 'r_{u1}' indicates the switching signal of the top switch of phase "R" of the inverter 1.

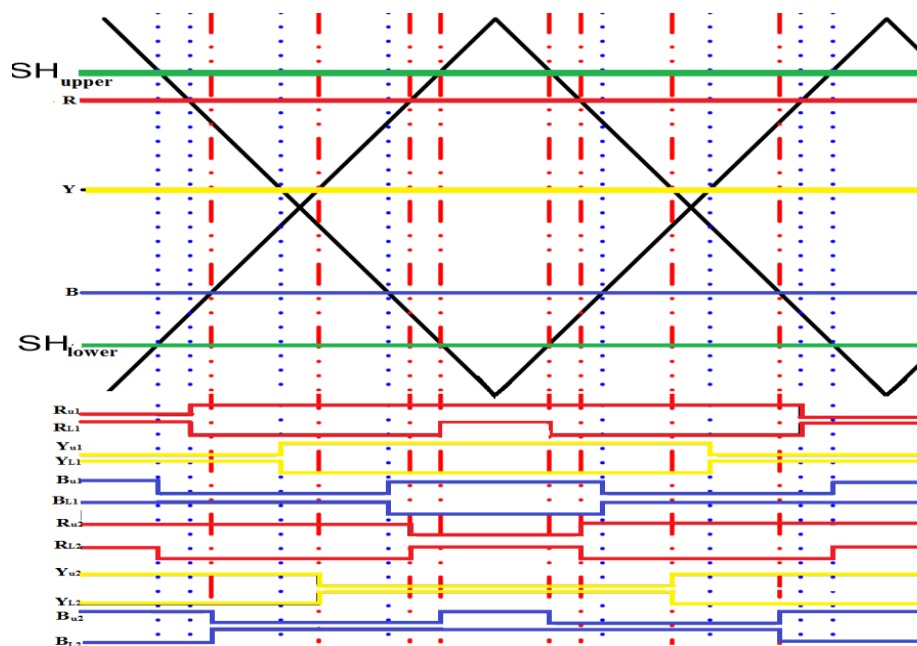

Fig 3: Generation of switching signals with interleaved carrier-based PWM^[1]

There are a few controlling techniques applicable for grid-connected parallel inverter systems, some of them are master–slave control, active–reactive power control, and conventional droop control. Where each inverters will be delivering equal amount of power to the system, hence a common reference signal is needed. Hence, both droop and active–reactive power controlling techniques are suitable. The master–slave type controller will lead to complicated control technique, due to the presence of shoot-through states. It need to be inserted in all the inverter switching periods. Furthermore, this scheme will increases the possibility of expansion.

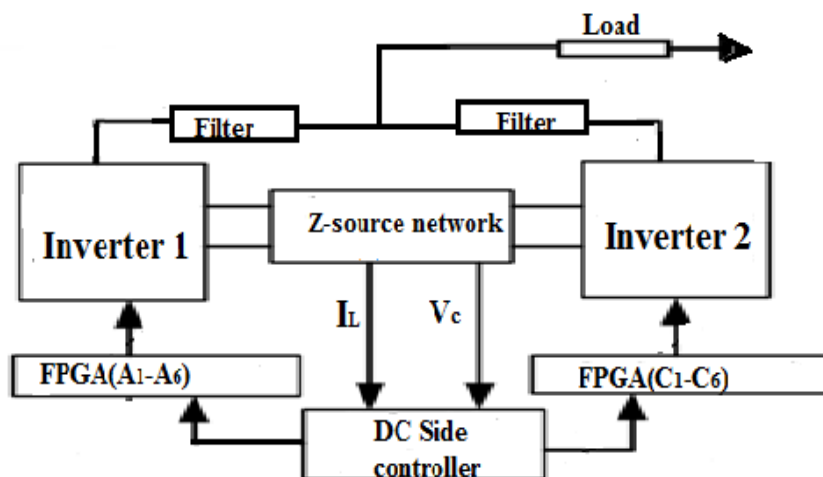

Fig 4: Closed-loop control system diagram of the Z-source inverter

The ac-and dc-sides of the inverters can be modeled separately. A technique is proposed to prevent the unwanted non-minimum-phase effects in the ac side. A paralleled inverter system is introduced. Generally the circulating current can be controlled with the help of a zero-sequence controller which can adjust the null intervals to remove the zero sequence component. Whereas in this proposed system this method is not applicable because here the null intervals are used for shoot-through. The controller for the two subsystems can be design independently. Fig 4. shows the closed loop diagram of the proposed topology where dc side is represented by a separate circuit. Fig. 5.shows the overall control diagram of the proposed system. The dc-side controller is made common to the two inverters. The control method is implemented to supply a steady voltage input to the inverters while rejecting disturbances arising from both the input. The shoot-through time is taken as a control variable. By adjusting the shoot through period the output can be varied from zero to infinity.

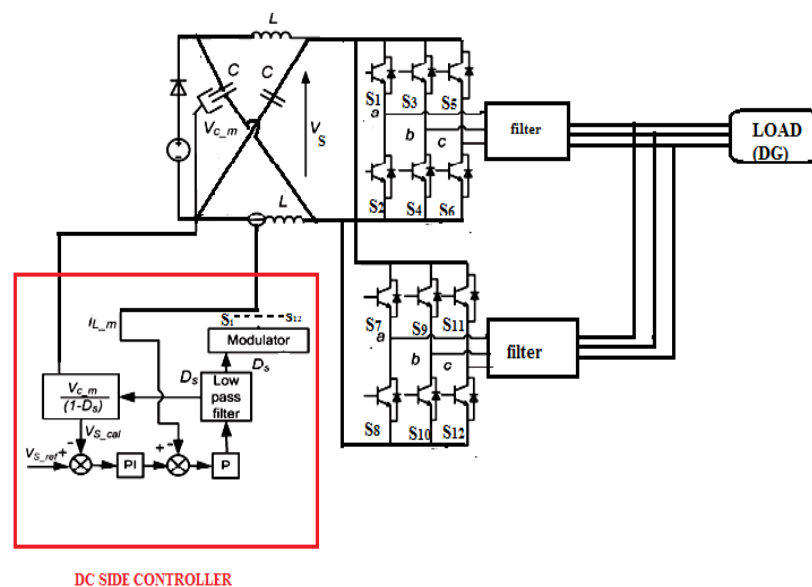

Fig 5: Overall control diagram^[2]

The controller is designed to integrate DG sources with varying output dc voltages to the grid connected system. The dc-side controller is designed to produce a boosted voltage and provide a steady supply to the inverter while achieving fast recovery from disturbances. Fig.3.3 shows the simplified diagram of dc side of the inverter system. The equivalent dc-side current is transformed to the synchronous reference frame. The proper control of zero-sequence current can be done, hence zero current condition is vanishes and the circuit becomes similar to the dc-side controller. Normally, an indirect controller with inner current loop and outer voltage loop is employed in all other systems. Here, the inner loop uses a proportional controller with $k_p = 0.1$ and outer loop uses PI constants of $k_p = 0.01$ and $k_i = 1$. The output voltage of the Z-source impedance network is pulsating, the equivalent value of the voltage is derived using the measured voltage across one of Z-source capacitors and shoot-through time.

Table 1: Parameter specifications of system

11) Parameter	Specifications
Inductor (L_1, L_2)	15mH
Capacitor (C_1, C_2)	120 μ F
Output Power	373W
Output Voltage	400V
Input Voltage	200V

IV. SIMULATION RESULTS

Simulations have been performed to confirm the analysis. The input dc voltage (renewable voltage) is $V_{dc}=200$ V and the Z-source parameters are inductances (L_1 & L_2) of 15.4mH and capacitances (C_1 & C_2) of 120 μ F. The purpose of this system is to produce a three-phase 373W peak power from dc depending on the load current. From the simulation waveforms, it is clear that the capacitor voltage was boosted to $V_C=1108$ V and the output 400 V peak. In this case, the modulation index was set to $M=0.59$, and the shoot-through duty cycle was set to $T_0/T=0.348$, and switching frequency was 10 kHz. The shoot-through zero state was populated evenly among the three phase legs, achieving an equivalent switching frequency of 60 kHz viewed from the Z-source network. Therefore, the required dc inductance is minimized.

The simulation of a parallel Z source inverters is done using MATLAB. MATLAB is a high performance language for technical computing. It integrates computation, visualization and programming in an easier environment where problems and solutions are expressed in familiar mathematical notation. MATLAB is specially designed simulation software for power electronics and motor drive. By using MATLAB, various converter configurations can be modeled and compared

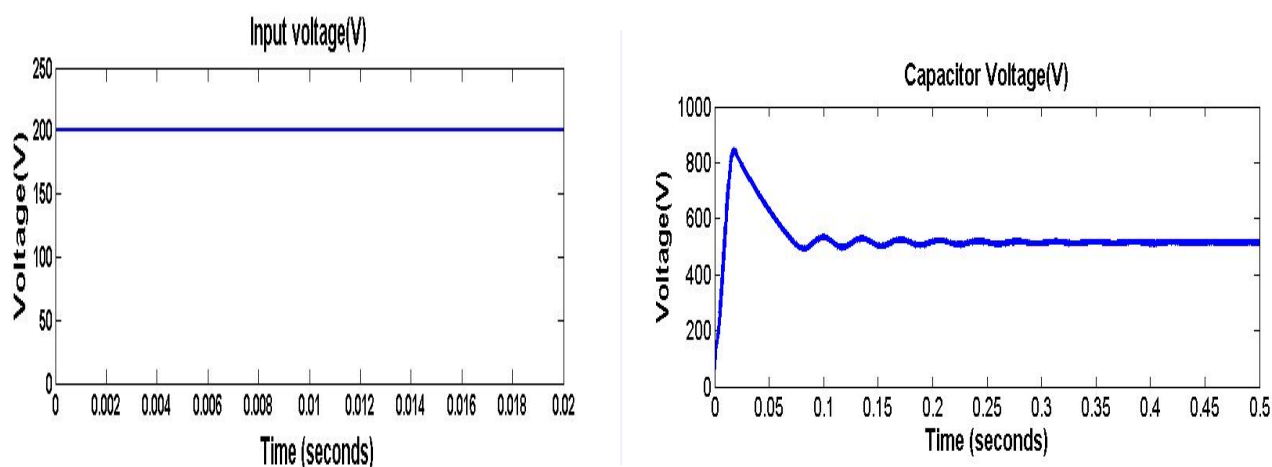

Fig 6: Input Voltage and capacitor voltage

Fig 6.shows simulated input dc voltage results for input voltage, appropriate selection of the modulation index(M) and saturation limits suited for a giveoperating range is necessary.

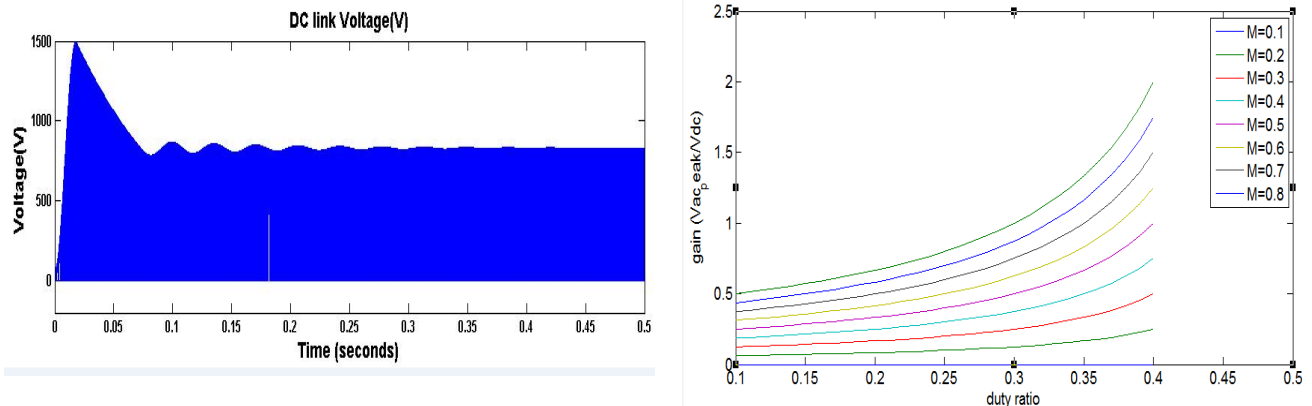

Fig 7: DC link Voltage & Gain Vs d_s

Capacitor voltage V_c is shown in the figure 7, where $V_c=600V$ and the dc link voltage $V_{dc_link}=950V$. The output voltage is boosted with a boost ratio $B=4$. The capacitor voltage and dc link voltage depends on the duty ratio D_s .

The closed loop system consists of a dc side controller, where the capacitor voltage and inductor current is measured and feedback to obtain the required shoot through d_s . With properly designed controllers, the dc-side have minimum disturbance. This dc side controller will reject all the disturbances arising from the input side. However, to achieve desirable DC-side responses, from top to bottom, output voltage of Z-source impedance network, voltage across the Z-source capacitor, and inductor current. Appropriate selection of the modulation index and saturation limits suited for a given operating range is necessary. These parameters are obtained from the closed loop simulation itself. The dc side controller is designed to minimize the disturbances in the input side, the disturbances mainly affects the dc link voltage. So it has to stabilize the dc link voltage. Fig 8. shows the stabilized dc link voltage. The dc link voltage is twice the capacitor voltage. And the control loop has to settle down the dclink voltage to a reference value.

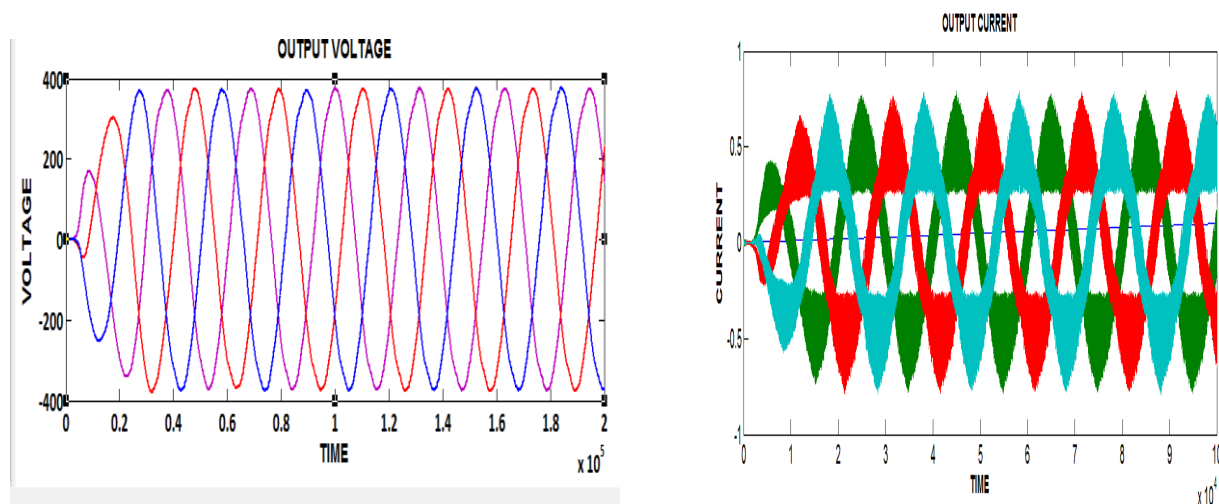

Fig 8: AC output voltage & current

The three phase output voltage is obtained as 400V. And the output current is improved as compared to dc open loop system. The range of output voltage can be vary from zero to infinity. This is specialty of the Z source network. The maximum boost factor is the product of modulation index and boost factor. Overall, the designed closed-loop controllers exhibit excellent reference tracking, disturbance rejection, and the balanced power sharing properties. The simulation study of the system shows the variation of output voltage with input depending upon the modulation index and duty ratio. For a particular modulation index the gain has a graph as shown in Fig 5.16. The gain is the ratio of output ac voltage to input dc voltage. As modulation index increases the gain also increases. Based on these results a prototype model of the system is developed.

V. HARDWARE IMPLEMENTATION AND RESULTS

The control algorithm for three phase paralleled z source inverter is developed using the controller DSPIC30F2010 &FPGA. Hardware implementation of the circuit includes three sections such as Z source network, two inverter circuits, and paralleling he inverters. The circuit parameters of Z source inverter is designed to achieve a boosted output voltage at AC mains which can be used to distributed generation system. A prototype of the proposed paralleled Z-source-inverter is built in the laboratory. Response of the Z-source inverter isobtained when a input voltage is applied $V_{dc}=100V$, output voltage of the Z-source impedance network, voltage across the Z-source capacitor are measured. The capacitors and inductors for the Z-source impedance network are selected to avoid the Z-source inverter going into unwanted states. A resistive load bank is used as the load.The network consists of two inductors and two capacitors. These are designed and build. The inductor is split inductor thus both of them having same value. By area product method it is designed and obtained as 15.4 mH. It is having 220 turns. The input inductor is of very high value and this inductor reduces the input current ripples. Inductors of E42 are used. Two polymer capacitors are used as shown in the figure with 120 μ F. Capacitor of electrolytic type is used as the DC-link capacitor. Diodes UF5408 of very high rating is used as the Diode in the input side, which is to prevent the reverse current flow during shoot through.

The twelve switching pulses for two inverters are generated by programming. The specialty of the signals is that they are with shoot through intervals. A lengthy program is generated to obtain these signals which are given in the appendix. The shoot through pulses are inverted in the controller because the Tlp250 will invert the signal once more.

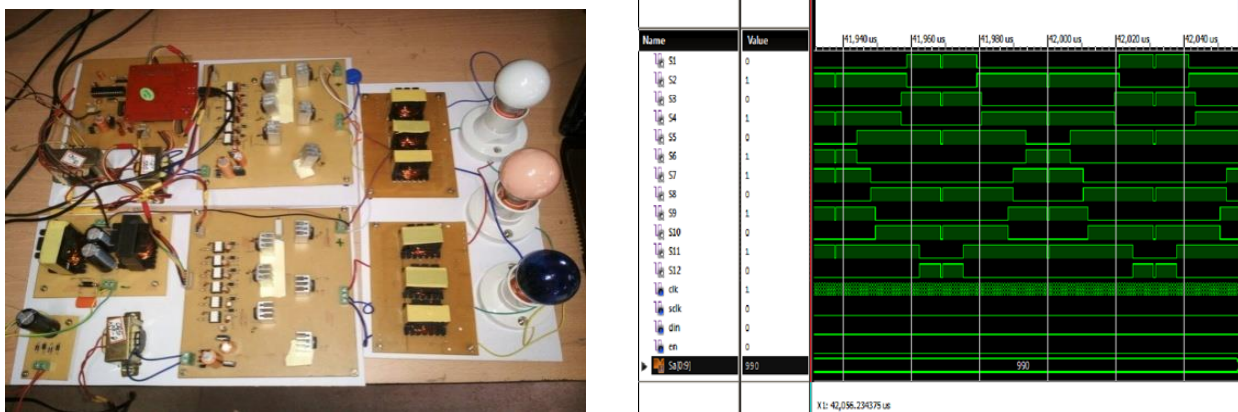

Fig 9: Experimental setup and simulation pulse

The experimental setup consists of three major sections they are the Z source network, inverters and the controllers as shown in the fig 9.The AC supply is given through an autotransformer to the Z source network through a diode bridge rectifier circuit. Input of 100V is given to the z source network. The Z source converts this 100 to 167V DC. The DC voltage obtained is given to the Inverter circuits. Sine interleavedPWM technique is used in the inverters. Two filter circuits are placed in the output side parallel with the R load network. The experimental setup was done and the following results were obtained. The fig .10 shows the input voltage waveform. The input voltage is pure dc. The controller provides the necessary gate signals for the two inverters and the inverter gate pulses are observed in the DSO and it is shown in the Fig 10.

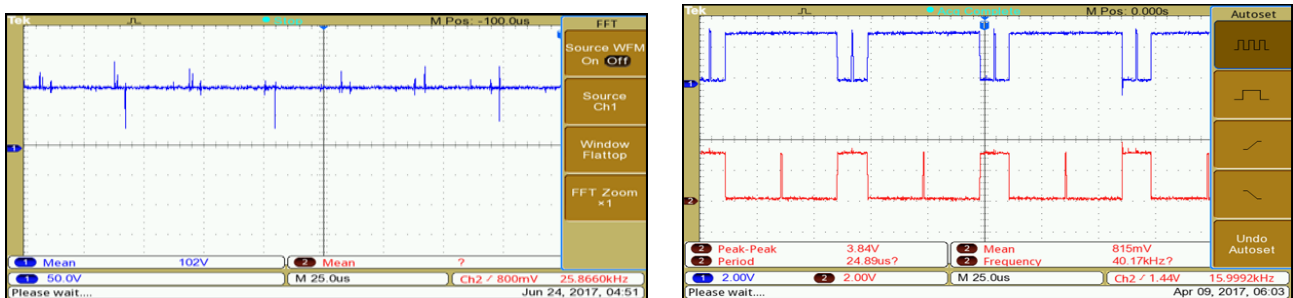

Fig 10: Input voltage waveform and switching pulses.

The shoot through is very clear in this waveform. Normally when switch S_2 is in OFF state during the conduction period of S_1 . Here the shoot through is purposefully inserted, due to that S_2 is turned on and switches in the same arm conducts with the help of Z source network. Thereby the output voltage is increased as compared with VSIs.

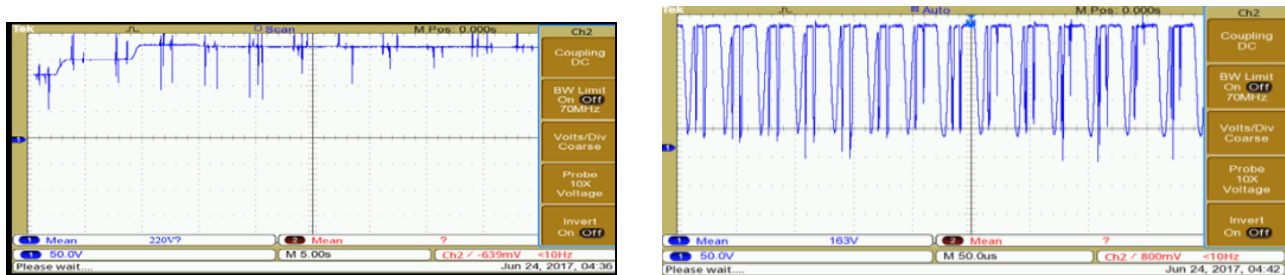

Fig 11: Capacitor voltage and dc link voltage

Capacitor Voltage is obtained as 220 V and this is the boosted voltage. The step change in this capacitor voltage graph indicates that it changes with input voltage and get stabilized. The capacitor voltage depends on the duty ratio. Hence by adjusting the duty ratio the disturbances in the system can be introduced. And hence analyze the disturbance rejection of the proposed system. This is tested in the open loop system. In closed loop system the duty ratio is automatically adjusted by the control circuit, The main aim of the DC side controller is to stabilize the input of the inverter that is the dc link voltage. And which is successfully obtained by feedback control. The dc link voltage is obtained as 163 V as shown in the figure.

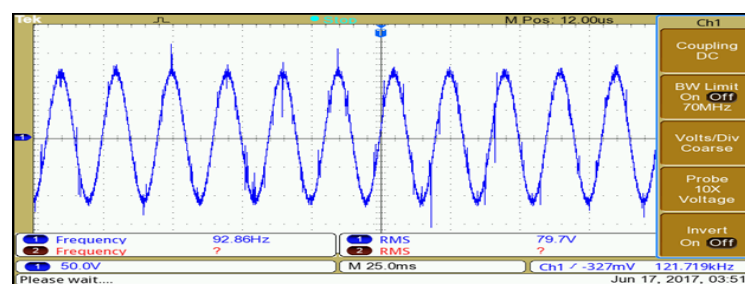

Fig 12: Output voltage

Output voltage of 120V is obtained at the converter output and it is shown in the Fig 12. The AC output obtained across the load terminals. The duty ratio is taken as 30%. Hence the boosted voltage is 120V. By increasing the duty ratio or modulation index the outputs is varied in a large scale.

VI. CONCLUSION

A carrier-based modulation method is proposed and the modulation method is designed based on simple shoot-through with interleaved carrier signals. Based on the mathematical model of the Z-source inverter described in transfer functions, controllers are designed for dc side of the inverter. The dc-side controller is designed to supply a constant input voltage to the inverters while rejecting disturbances from the supply side by varying the shoot-through time appropriately. The simulation of the entire system is completed and obtained results is match with the expected one. The future work is to implement the ac side controller. Then it can connect it with grid connected systems. In that field the proposed system has great advantages such as power quality improvement etc. And here It is having two inverters in the system thus if one of them failed to operate the other one will compensate. And if the system connects with grid the inverters will perform harmonic mitigation also. And if it is connected to the grid the inverters will perform harmonic mitigation too. Furthermore, with open-loop and closed-loop simulations, it was observed that there is a possibility of the dc-side effects being transferred into the ac-side. These characteristics impose complications in designing the controllers. However, it is countered with proper selection of parameters and with the adoption of a novel cushioning technique for the modulation index. The ac- and dc-sides are considered as separate units, and the controllers were designed to achieve good voltage regulation and disturbance rejection. Thus it is seen that the system can be very well suited to grid-tied distributed generation systems.

REFERENCES

- [1] D. Mahindra Vilathgamuwa, Senior Member, IEEE, "Modulation and Control of Three-Phase Paralleled Z-Source Inverters for Distributed Generation Applications." IEEE Transactions On Energy Conversion, Vol. 24, No. 1, March 2009
- [2] C. J. Gajanayake, D. M. Vilathgamuwa, and P. C. Loh, "Development of a comprehensive model and a multiloop controller for Z-source inverter DG systems," IEEE Trans. Ind. Electron., vol. 54, no. 4, pp. 2352–2359, Aug. 2007.
- [3] S. Rajakaruna, Member, IEEE and Y. R. L. Jayawickrama, "Designing Impedance Network of Z-Source Inverters", School of Electrical and Electronic Engineering, Nanyang Technological University, 2005.
- [4] V. Ramanarayanan, "Switched Mode Power Conversion", Department of Electrical Engineering, Indian Institute of Science, Bangalore December 2, 2007.
- [5] F. Z. Peng, "Z-source inverter," IEEE Trans. Ind. Appl., vol. 39, no. 2, pp. 504–510, Mar./Apr. 2003.
- [6] F. Z. Peng, A. Joseph, J. Wang, M. Shen, L. Chen, Z. Pan, E. Ortiz-Rivera, and Y. Huang, "Z-source inverter for motor drives," IEEE Trans. Power Electron., vol. 20, no. 4, pp. 857–863, Jul. 2005.
- [7] Z. Ye, D. Boroyevich, J.-Y. Choi, and F. C. Lee, "Control of circulating current in two parallel three-phase boost rectifiers," IEEE Trans. Power Electron., vol. 17, no. 5, pp. 609–615, Sep. 2002.
- [8] J.-W. Jung, M. Dai, and A. Keyhani, "Modeling and control of a fuel cell based Z-source converter," in Proc. 22th Annu. IEEE Appl. Power Electron. Conf. (APEC), Expo., Austin, TX, 2005, pp. 1112–1118.
- [9] Z. Chen and E. Spooner, "Simulation of a direct drive variable speed energy converter," presented at the Int. Conf. Electr. Machines, Istanbul, Turkey, 1998.
- [10] M. Prodanovic, T. C. Green, and H. Mansir, "A survey of control methods for three-phase inverters in parallel connection," in Proc. 8th Int. Conf. Power Electron. Variable Speed Drives, London, U.K., 2000, pp. 472–477.
- [11] T.-P. Chen, "Circulating zero-sequence current control of parallel three-phase inverters," Inst. Elect. Eng. Proc. Elect. Power Appl., vol. 153, no. 2, pp. 282–288, Mar. 2006.
- [12] P. C. Loh, D. M. Vilathgamuwa, Y. S. Lai, G. T. Chua, and Y. Li, "Pulsewidth modulation of Z-source inverters," in Proc. 39th Annu. IEEE Ind. Appl. Conf. (IAS 2004), pp. 148–155.
- [13] J. Wang, F. Z. Peng, J. Anderson, A. Joseph, and R. Buffenbarger, "Low cost fuel cell converter system for residential power generation," IEEE Trans. Power Electron., vol. 19, no. 5, pp. 1315–1322, Sep. 2004.
- [14] M. Thomson and D. G. Infield, "Impact of widespread photovoltaics generation on distribution systems," IET Proc. Renewable Power Generation, vol. 1, no. 1, pp. 33–40, Mar. 2007.
- [15] X. Yu, M. R. Starke, L. M. Tolbert, and B. Ozpineci, "Fuel cell power conditioning for electric power applications: a summary," IET Proc. Elect. Power Appl., vol. 1, no. 5, pp. 643–656, Sep. 2007.
- [16] N. Yamamura, M. Ishida, and T. Hori, "A simple wind power generating system with permanent magnet type synchronous generator," in Proc. IEEE Int. Conf. Power Electron. Drive Syst. (PEDS 1999), Hong Kong, pp. 849–854.
- [17] J.-W. Jung, M. Dai, and A. Keyhani, "Modeling and control of a fuel cell based Z-source converter," in Proc. 22th Annu. IEEE Appl. Power Electron. Conf. (APEC), Expo., Austin, TX, 2005, pp. 1112–1118.